

**Adult Participation Form
Volunteers Needed For
HVAA 2010
Fall Soccer Season**

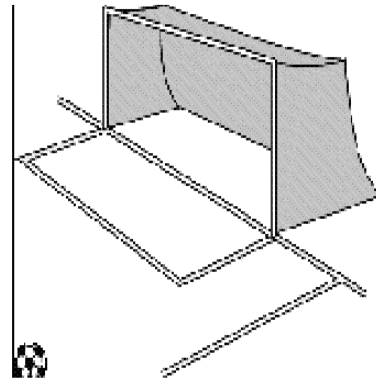
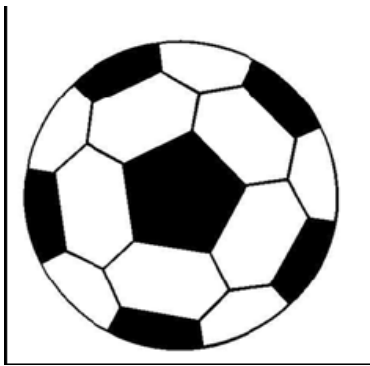

HVAA needs your timer and assistance to make our programs successful. Coaches, Assistant Coaches and League Commissioners are needed. No experience is necessary. HVAA will provide guidance and assistance along the way. Please continue to support your community by volunteering to help this activity.

Volunteer's Name _____

____ I do have a child participating that I wish to coach.

____ I do not have a child participating that I wish to coach.

_____ Player's Name (if applicable)

_____ Player's Age (if applicable)

_____ My Phone Number

_____ My email address

I am volunteering to perform the following function (select all that apply) _____ Coach _____ Assistant Coach _____ League Commissioner _____ Other (please explain on reverse side of this form)

Return volunteer forms with player registration forms, or mail to: HVAA, Attention: Director of Baseball/Softball, PO Box 155 Huntingdon Valley, PA 19006

Note: The Board of Directors of the Huntingdon Valley Activities Association maintains the sole and exclusive right to select all coaches for its programs. Signing this form or volunteering to coach does not guarantee selection. HVAA reserves the right to recruit additional persons to coach. All prospective coaches must complete the HVAA Coaches Class and execute a Coach's Code of Conduct before any person is eligible for consideration.



HUNTINGDON VALLEY ACTIVITIES ASSOCIATION

P.O. Box 155

HUNTINGDON VALLEY, PA 19006

(215) 947 - 9823 • <http://www.hvaa.net>

SPONSORSHIP FORM

HVAA Needs Your Support !

To keep our registration fees reasonable and to provide quality programs, HVAA relies on individuals and businesses to sponsor our activities. Please help us help our community!

Enjoy the benefits of sponsorship, which include:

- Appreciation for supporting the children's activities
- Fees may be tax deductible (consult your tax professional)
- Promotion of your business to the members of the community

Sponsorships Include:

- Name of your choice displayed prominently on the back of an entire team's jersey
- Sponsorship plaque with a photo of the team(s) you sponsor
- Invitation to HVAA's Annual Coaches and Sponsors Appreciation Banquet

Sponsorship Fees:

- One Team.....\$175
- Two Teams.....\$300
- Three Teams.....\$400
- Four Teams.....\$500

New Lower Fees!!

Questions? Contact us at 215-947-9823, and select Mailbox #5 for Sponsorship

Please complete, detach, and forward this form to us today!

Sponsorship Information

Sport (Select One) Baseball/Softball Roller Hockey Soccer Basketball
 Number of Teams Sponsored: 1 2 3 4 Other _____ Amount of Sponsorship: _____
 Company or Sponsor Name _____
 Address _____
 City _____ State _____ Postal Code _____
 Point of Contact _____
 Phone Number: _____ FAX Number _____ Email Address _____
 Exact name to appear on the back of the jersey: _____

Select one of the statements below:

- I do not have a child on the team(s) I am sponsoring.
- I do have a child on the team(s) I am sponsoring. My child's name is _____. He/she is _____ years old. (Note: If you are sponsoring more than one team and have children on those teams, please write their names and ages below)

2010 SOCCER REGISTRATION FORM
Huntingdon Valley Activities Association
P.O. Box 155
Huntingdon Valley, PA 19006
(215) 947-9823
www.hvaa.net

HVAA Use Only	
Cash/Money Order Amount	
Ck. # _____	Ck. Date _____
Ck. Amount _____	Late Fee _____
1 st 2 nd 3 rd 4 th	th Child

PLEASE FILL OUT COMPLETELY AND PRINT NEATLY

Comments: _____

- Interested in Travel Only. Not interested in playing in the In House League.
- Interested in Travel, but will play In House if I'm not selected For Travel.

- Please mark if this is the **FIRST** time you are registering your child in an HVAA activity.
- Please mark if the address and/or phone number listed below has changed since the **last time** you registered your child in an HVAA activity.

Child's Name: _____ Sex: M ___ F ___ Height: ___ FT. ___ IN.

Address: _____ Phone # _____

_____ Date Of Birth: ___/___/___ Age As of 9/1/2010: _____

_____ Grade You Will Be Entering In 2010/2011 School-year: _____

Please list two contacts HVAA can use to inform you of schedules, rosters and other pertinent details applicable to your child.

Contact 1: _____ Phone #: _____ Relationship to child: _____

Work Phone #: _____ Cell Phone #: _____

Contact 2: _____ Phone #: _____ Relationship to child: _____

Work Phone #: _____ Cell Phone #: _____

A family member has ___ has not ___ attended a mandatory HVAA Parent Education Class

Registration Fees and Dates (the postmark will determine if a Registration Form is considered late)

Final Deadline to register is July 31, 2010

Fee on or before June 30th (no late fee assessed): 1st Child - \$105, 2nd Child - \$85, Additional Children - \$70 each

Fee after June 30th (\$30 late fee per child assessed): 1st Child - \$135, 2nd Child - \$115, Additional Children - \$100 each

There will be an additional fee of \$50 for travel sports participants, collected if and when players are selected for the team.

Parental Waiver and Consent Form: As the parent or legal guardian of the above child, I hereby request and give my full consent and approval for my child to participate as a team member in the sport designated above. The risk of injury from the activities involved in this program is significant, including the potential for permanent paralysis and death, and while particular rules, equipment, and personal discipline may reduce this risk, the risk of serious injury does exist. I understand that risks of injury are inherent in the practice and play of this sport, as well as in traveling and other related activities incidental to my child's participation, and I am willing to assume these risks on behalf of my child, even if arising from the negligence or gross negligence of the releases or others, and assume full responsibility for my child's participation. I hereby certify my child is fully capable of participating in the designated sport and my child is healthy and has no physical or mental disabilities or infirmities that would restrict full participation in these activities. In addition to giving my full consent for my child's participation, I do hereby waive, release and hold harmless the organization named above, its officers, coaches, sponsors, supervisors and representatives for any injury that may be suffered by my child in the normal course of participation in the designated sport and the activities incidental thereto, whether the result of negligence, gross negligence or any other cause. I have read this registration/consent form. I give full consent for my child's participation.

Child Participation: Under HVAA rules, any child may be prohibited from participating in future programs if he/she does not attend at least 75% of all games and practices.

Refund Policy: If you wish to withdraw your child from the program and request a return of your registration fee, you must submit your request in writing by regular mail at P.O. Box 155, Huntingdon Valley, PA 19006, postmarked on or before August 10th, 2010. Requests after that date will not be honored. A \$10 processing fee will be deducted from all refunds.

Game Scheduling: Due to limited availability of facilities and the uncertainty as to the number and/or ages of children registering for the sport, game and practice schedules cannot be determined until after the drafting of teams occurs.

Parent/Guardian Signature: _____ Date: _____ (MUST BE SIGNED & DATED!)

- Please mark if the E-mail address listed below has changed since the **last time** you registered your child in an HVAA activity.

Parent/Guardian E-mail address: _____ (PLEASE PRINT NEATLY)

By signing this registration form, children, parents and coaches agree to comply with HVAA's code of conduct. The Board of Directors reserves the right to refuse to register any child for any reason and to remove any child from any activity at any time.